

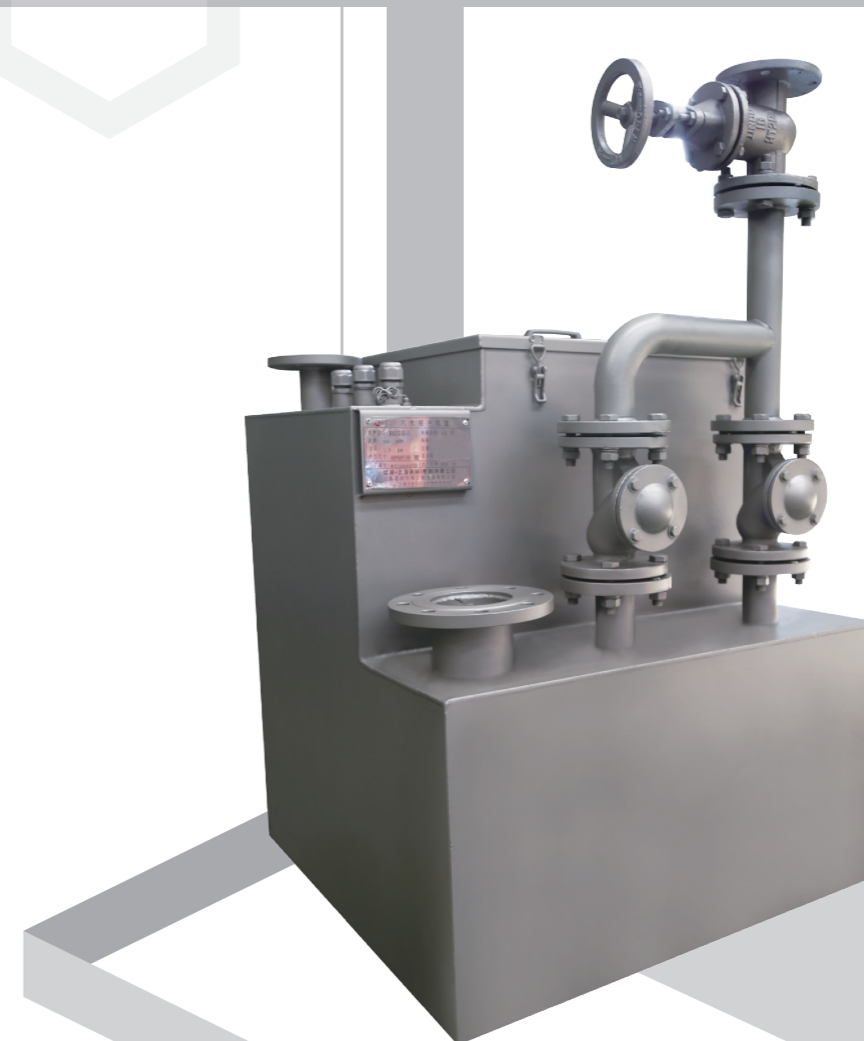

# WTG小型污水提升装置

WTG SMALL SEWAGE LIFTING DEVICE



**上海连成（集团）有限公司**  
SHANGHAI LIANCHENG (GROUP)CO.,LTD.

地址：上海市江桥镇曹安公路3616-3618号  
邮编：201812  
总机：(021) 59138888  
传真：(021) 59136782  
800免费咨询电话：800-820-5009  
400免费咨询电话：400-188-5009

Address:3616-3618 Cao'an Road,Jiangqiao Shanghai  
P.C.: 201812  
Switchboard: (021) 5913888  
Fax: (021) 59136782  
800 Free consultation Tel: 800-820-5009  
400 Free consultation Tel: 400-188-5009



连成集团微信订阅号



上海连成(集团)有限公司，是一家国内著名的研究制造泵、阀和流体输送系统、电气控制系统和环保设备的多元化经营的大型集团企业。

经过十多年的发展，现已拥有五大工业园区，分布于上海、江苏和浙江等经济发达地区，总占地面积达55万平方米，总部设在上海封浜工业园区。旗下拥有上海连成泵业制造有限公司、上海连成电机有限公司、上海连成阀门有限公司、上海连成集团物流有限公司、上海连成集团通用设备安装工程、上海阿美泰克工业设备有限公司、上海连成集团环境工程设备有限公司、上海连成集团苏州股份有限公司等多家全资子公司及控股公司，注册资金达5.8亿元以上，总资产达数十亿元。产品品种现已达三千多种，涵盖水泵、电机、电气柜、阀门、成套设备、机械配件等系列，其产品性价比高，质量可靠，广泛应用于市政、水利、建筑、消防、电力、环保、石油、化工、矿业、医药等领域。集团销售业绩每年均为行业前茅。

集团公司目前拥有大型水泵测试中心、三坐标测量仪、动静平衡测量仪、激光快速成型仪、多功能抛丸机、自动氩弧焊机、大型立车、大型磨床、数控机床集群等各种国内外先进的生产检测设备2000台套以上。现有员工4500余人，大中专

Shanghai Liancheng (Group) Co., Ltd is a domestic well-known large group enterprise and its multiple operations cover the research and production of pumps, valves and fluid transportation systems, electric control systems and environmental protection equipments.

After ten years development, the group holds five industrial parks in Shanghai, Jiangsu and Zhejiang etc. areas where the economy has been greatly developed, covering a total land area of 550 thousand square meters. Its headquarters is located at Fengbang Industrial Park and under it there are several wholly owned subsidiaries and holding companies: Shanghai Liancheng Pump Manufacturing Co. Ltd, Shanghai Liancheng Motor Co. Ltd, Shanghai Liancheng Valve Co. Ltd, Shanghai Liancheng Group Logistics Co. Ltd, Shanghai Liancheng Group General Equipment Installation Engineering, Shanghai Ametek Industrial Equipment Co. Ltd, Shanghai Liancheng Group Environment Engineering Equipment Co. Ltd and Shanghai Liancheng Group Suzhou Co. Ltd, with the registered capital up to 5.38 billion CNY, the total capital up to tens of billion CNY and the product categories up to more than 3000, ranging from water pump, motor, electric cabinet, valve, completed equipment, mechanical accessories etc. series, and, because of the reasonable performance-price and reliable quality, broadly used in the fields of municipal works, water conservancy, architecture, fire-fighting, electric power, environmental protection, petroleum, chemical industry, mining and medicine. The sales incoming of this group ranks first in the industry every year.

The group company now holds a large pump test center, a three-coordinate measurer, a dynamic-static measurer, a quick laser shaping instrument, a multi-functional shot-blasting machine, an automatic argon-arc welder, a large lathe, a large mill, numeral control machine tools etc. more than 2000 sets of various nationwide and world wide advanced production and detection facilities and over

## 企业简介 CORPORATION OUTLINE

生占72.6%，其中中级职称者475人、高级职称者78人、国家级专家19人、教授6人。每年都投入大量资金用于技术创新、产品开发和设备引进，持有国家专利技术近达600余项，每年均参与大量的国家及行业标准起草及编写工作，涉及水利、化工、消防、城市供水等各领域的产品及技术标准累计达数十部。集团建有完善的销售服务网络，设有30余家分公司及200多个分支机构，拥有一支2800多人的专业销售服务队伍，为广大客户提供专业的技术支持与优良的营销服务。

集团通过了ISO9001、ISO14001、OHSAS18001等国际管理体系认证，全面推行ERP信息化管理；先后获得国家 and 行业颁发的工业、消防、煤矿、石油化工等重要领域的工业产品生产许可证、CCC中国国家强制性产品认证、CQC产品认证、CE认证、卫生许可批件、MA煤安认证、SMA计量合格认证、节能认证、节水认证、采用国际标准认证、进出口企业资格等生产经营资质；并获得了“国家级创新型企业”、“中国驰名商标”、“上海市著名商标”、“上海市名牌产品”、“中国著名品牌”、“大型企业”、“国家首批水泵节能认证通过企业”、“上海市高新科技企业”、上海“市级企业技术中心”、“上海市知识产权示范企业”、“上海市民营制造业50强”、“上海市百强工业企业”、“国家标准起草单位”、“中国水工业十大民族品牌”等众多的社会荣誉。

随着连成集团的永续经营，连成产品得到了用户广泛认可，目前拥有：国家体育场“鸟巢”、国家大剧院、上海世博工程、首都机场、广州白云机场、上海地铁、西安地铁、沈阳地铁、香港供水工程深圳沙湾泵站、澳门供水工程珠海平岗泵站、黄河灌溉山西夹马口泵站、山西省西范泵站、广东云安六都泵站、黄河小浪底水利工程、宁夏扬黄灌溉工程、鄂尔多斯多座城市饮水工程、秦山核电、岭澳核电、国电集团、大唐电厂、华能电厂、宝钢、首钢、唐钢、太钢、鞍钢、新疆八一钢铁、大庆油田、青海盐湖钾盐项目、山西焦化、潞安矿业、陕西咸阳化工、中海油惠州炼油项目、清华大学、海尔集团和安哥拉农业排灌工程、缅甸国家农业灌溉项目，以及核电、火电、水电、钢铁、油田、焦化、矿业、化工、炼油等一大批国内、外样板工程。在通用、拜耳、西门子、大众、可口可乐等国际知名企业在中国的工程均采用了连成集团的产品。

连成集团矢志于打造世界顶级流体处理工业企业，秉承永远珍惜人与自然和谐关系、为提高人类生活质量不懈努力的宗旨，为实现“百年连成”远大目标，一直致力于环保型、节能型产品的研发与制造，为民族企业的振兴与发展不懈努力！

水，因连成至高致远……！

4500 staff members, of which 72.6% are graduated from colleges and technical schools, 475 hold a junior title, 78 senior, 19 national experts and 6 professors. Every year this group puts a number of capital for technical innovation, product development and equipment import and, up till now, holds up to 600 national patent technologies and takes part in the draft-out and edition of both national and industrial standards, in total of tens of tens of the product and technical standards covering water conservancy, chemical industry, fire-fighting, city water supply etc. fields. This group has set up a complete sales and service networks, comprised of 30 branches, more than 200 sub-organs and a group of 2800 special salesmen and servicemen, to provide the clients with special technical support and good business services.

Accredited to ISO9001, ISO14001, OHSAS18001 etc. international management system arrivals, this group is striving to implement ERP Information Management and has got the industrial production licenses in industry, fire-fighting, petrochemical, and mining etc. important fields issued by the state and the industry organization and the qualification as an I/E enterprise, been accredited to CCC, CQC product, CE, sanitation permit, MA mine safety, SMA gauging qualification, energy-saving, CCS, adoption of international standard etc. lots of approvals and awarded with the social honors such as: National-grade innovative brand-new enterprise, Chinese Famous Trademark, Shanghai Well-Known Trademark, Products of a famous brand of Shanghai, Famous brand of China A large enterprise, Enterprise in the first lot passing the pump energy-saving approval, A high-tech enterprise of Shanghai, Technical center of the enterprise in the city's level of Shanghai, An example enterprise for the intellectual property of Shanghai, One of the 50 powerful enterprises of Shanghai, One of the private technical enterprises of Shanghai, An enterprise qualified for the draft-out of the national standard, Ten national brands in the water industry of China and so on.

With the steady development of Liancheng Group, the products made therein have been greatly accepted by the users and now available with: the National Stadium Birdnest, the National Theatre, Shanghai Expo, the Capital Airport, Guangzhou Baiyun Airport, Shanghai Metro, Shenyang Metro, Xi'an Metro, Hongkong Water Supply Project Shenzhen Shawan Pump Station, Macao Water Supply Project Zhuhai Pinggang Pump Station, Huanghe River Irrigation Shanxi Jiamakou Pump Station, Shanxi Xifan Pump Station, Guangdong Yun'an Liudu Pump Station, Xiaolangdi Water Conservancy Project in Yellow River, Ningxia Yanghuang Irrigation Engineering, E'erduosi City Drinking Project, Qinghai Salt Lake Sylvine Project, Qinshan Nuclear Power, Ling'ao Nuclear Power, National Power Group, Huaneng Power Plant, Datang Power Plant, Baoshan Steel, Capital Steel, Tai Steel, Anshan Steel, Xinjiang Bayi Steel, Daqing Oil Field, Shanxi Coking, Lu'an Mining Industry, Shanxi Xianyang Chemical Industry, China Marine Fuel Huizhou Refinery Project, Tsinghua University, Haier Group and Angola Agriculture Drainage and Irrigation Project, the national agricultural irrigation project of Burma, as well as nuclear power, thermal power, hydro-power, steel-iron, oil field, coking, mining, chemical, refinery, and in the projects set inside of China by GE, Bayer, Siemens, Volkswagen, Coca-cola etc. worldwide famous enterprises.

Liancheng Group has been trying its best to make itself a top fluid treatment enterprise in the world and follow such a concept as cherishing the harmony between human and nature forever and, to improve the people's living level and realize the great goal of a century-lasting Liancheng, making efforts for both development and manufacture of the environmental-protection and energy-saving products and for both promotion and progression of the national enterprises!

Water, flowing high and far to the utmost just because of Liancheng……



中国驰名商标



上海市著名商标



国家级创新型企业

# 目 录

## CONTENTS

<b>产品概述</b> Product overview	1
<b>使用范围</b> Use range	1
<b>技术参数</b> Technical parameters	1
<b>产品特点</b> Product features	2
<b>技术要点</b> Technical key points	2
<b>型号意义</b> Model meaning	3
<b>使用条件</b> Condition of use	3
<b>工作原理</b> Working principle	4
<b>XWT型污水提升装置结构图</b> Structure diagram of XWT type sewage lifting device	6
<b>性能参数表</b> Performance parameter	7
<b>性能曲线图</b> Performance curve	8
<b>外形及安装尺寸图表</b> Shape and installation dimension chart	9

## 产品概述 Product overview

该设备适合作为别墅地下室卫生间排水和建筑卫生间改造排水的解决方案，建筑改建设有排水管道，别墅地下室增加卫生间，小型家庭用和大型公共卫生间的都可以通过的“连成”污水提升装置系列产品解决！“连成”污水提升装置，类似一个活动的污水处理提升站，全面替代传统的挖积水坑，设置污水泵的方式，另外污水提升器还配有洗衣房排水专用设备。使用带切割刀的高效排污泵，在污水中的杂物进入水泵前就将其切割成小块，避免水泵产生堵塞和缠绕，其密封状态下的污水排放更是对环境起到极好的保护。本产品采用的是全密封，不锈钢材质的污水储存箱，以及独特的通气方式，所以对周围环境没有任何影响，起到环保作用。污水提升器高标准的质量保证，确保更长的使用寿命。

The device is suitable for as a solution to the villa basement toilet drainage and building reconstruction of the toilet drainage, reconstruction of building no drains, villa in the basement of the toilet is increased, small families and large public bathrooms are available through the "Liancheng" sewage lifting device series products to solve! "Liancheng" sewage lifting device, similar to a sewage lifting station, fully replace traditional digging accumulation sump, sewage pump set, also sewage lifter with laundry drainage and special equipment. Use with a high efficiency sewage pump, sewage in the debris into the pump before cutting into small pieces, to avoid the pump to produce a plug and winding, and its sealing state of the sewage discharge is more than the environment to protect the environment. This product uses a full seal, stainless steel material of the sewage storage tank, as well as the unique ventilation mode, so the environment has no effect on the environment, play a role in environmental protection. To upgrade sewage high standards of quality assurance, ensures longer service life.

## 使用范围 Use range

居民用水：生活小区，别墅区等  
 公共场所：学校，医院，车站，机场，剧院，体育馆等  
 商用场所：宾馆，酒店，饭店，商场，写字楼等  
 生产场所：制造企业，加工企业，石油化工等

Residential water: residential area, villas, etc.  
 Public places: schools, hospitals, stations, airports, theatres, stadiums, etc.  
 Business premises: hotels, hotels, restaurants, shopping malls, office buildings, etc.  
 Production sites: manufacturing enterprises, processing enterprises, petrochemical, etc.

## 技术参数 Technical parameters

- 1、最高扬程：33米；
- 2、最大流量：35立方米/小时；
- 3、总功率：0.75KW—15KW；
- 4、水泵为“连成”切割排污泵，防护等级为IPX8，潜水电机；
- 5、泵站名义容积：250-1000升（250L/400L/700L/1000L）；
- 6、带刀头的切割型排污泵在容器默认自耦式安装（可选其他安装方式，须协商），更换和维修更加方便；
- 7、250L型为单泵运行，其他型号采用双泵安装方式，可以交替运行，又可在进水量大时同时使用。

1. The highest head: 33 meters;
2. Maximum flow: 35 cubic meters / hour;
3. The total power: 0.75KW-15KW;
4. The pump for the "connected" cutting sewage pump, the protection level is IPX8, submersible motor;
5. Pump station nominal capacity: 250-1000L (250L/400L/700L/1000L);
6. With the knife head of the cutting type sewage pump in the container default self coupling type installation (optional other installation method, must consult), replacement and maintenance more convenient;
7. 250L type for the single pump operation, the other model uses the dual pump installation, can be used to run, and can be in the same amount of water when used.

## 产品特点 Product features

### 不堵塞:

采用特有切割刀头，长纤维进入水泵前被切断，从而水泵不会产生缠绕和堵塞，特别适合有长纤维或小颗粒的介质，延长水泵使用寿命。排水管部分可以采用小管径排水管而不堵塞，降低工程的土方工程量，节约空间和成本。

### 无污染:

设备全封闭设计，污水不外溢、设有专用排气管道，可以将设备内部气体排出到户外空间，无异味，保护周围环境。

### 远程监控（可选）:

根据客户需要，设备可选配远程监控系统，使值班人员足不出户，直观了解设备运行状态。设置内部液位浮球开关，配合自动控制箱，实现机组的自动启停和高液位报警等功能。

### 节约占地面积:

内置高效节能电机，机体小，可靠性高，整体设备占地面积小，安装灵活，节省土建投资成本，降低费用。

### Non blocking:

The use of special cutting knife head, long fiber into the water pump is cut off, so that the pump will not produce the wound and blockage, especially for long fiber or small particles of medium, prolong the service life of the pump. The drainage pipe can be used for the use of small diameter of the drainage pipe without blockage, reduce the amount of earthwork construction, save space and cost.

### No pollution:

Equipment design, the sewage does not overflow, with a dedicated exhaust pipe, the device can be discharged into the outdoor space, no smell, to protect the environment.

### Remote monitoring (optional):

According to customer needs, equipment can be optional remote monitoring system, the personnel on duty at home, an intuitive understanding of the running state of the equipment. Set up the inner liquid level float switch, with automatic control box, realize the automatic start stop and high level alarm and so on.

### Save the area:

high efficiency and energy saving motor, low body, high reliability, small size of the whole equipment, flexible installation, save the cost of civil engineering investment, reduce costs.

## 技术要点 Technical key points

污水提升装置250L规格配备一台切割式潜污泵，400L以上配备两台切割泵，通常采用耦合式安装（可选其他安装方式，须与技术中心协商）

切割泵出口水平，配套连成集团通用耦合适配器，实现耦合安装。两台泵可交替启动，互为备用，高水位时可双泵同时启动。

出厂前污水提升装置内已经装配好耦合底座和出水弯管，用户只需将耦合适配器安装到水泵出口，将泵沿导杆放到位，并正确使用相关密封件即可。

整套装置安装简单，日后检修方便，水泵具有切割绞碎能力。装置依靠内置三个浮球和一个油水探头分别控制停泵、启泵、双泵同启、高水位报警液位，需配套控制柜，装置控制精度和稳定性高。

The 250L standard of the sewage lifting device is equipped with a cutting type submersible sewage pump, and the 400L is equipped with two cutting pumps, which are usually coupled with the installation (optional other installation methods, and shall be negotiated with the technical center).

Cutting pump outlet level, supporting connected into a group of universal coupling adapter, coupled with the installation. Two pumps can be started to alternate with each other, and can be pumped at the same time.

Before leaving the factory, the utility model has been equipped with a coupling base and a water outlet pipe, the user only needs to install the coupling adapter to the pump outlet, and the pump will be placed along the guide rod, and can be used for the relevant seal.

The complete set of equipment is simple, and the maintenance is convenient in future, and the water pump has the ability of cutting and grinding. The device relies on a built-in three float ball and an oil / water probe to control the stop pump, start the pump, double pump with the start, high water level alarm level, need to complete control cabinet, device control precision and stability.

进水口有多种设置方式，后页图示为公司的常规配置方式，当有特殊需求或不同接口位置的时候，可以特殊提出，增加接口数量，尺寸，方向等。

Intake of a variety of settings mode, illustrated overleaf conventional configuration for the company, when there are special needs or different interface position can special request, increased the number of interfaces, size, direction, etc..

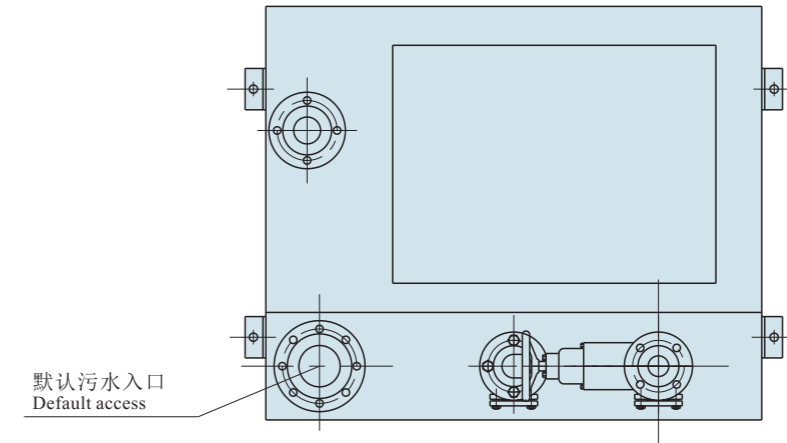

## 型号意义 Model meaning

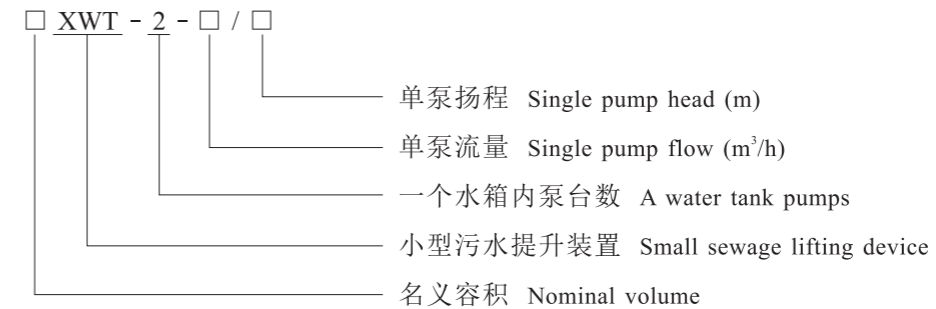

## 使用条件 Condition of use

1、电源频率为50Hz，三相交流380V。（220V电源需跟总部技术中心另行沟通确认。）额定电压和额定频率的偏差不得大于±5%。

2、污水中杂物（包括柔性杂物及小固体颗粒）须在管道内自行流动。

3、污水温度不能超过40℃，介质密度不超过1050Kg/m<sup>3</sup>（如密度超过此值需另行考虑配置潜污泵的系数），PH值在5-9范围内。

1. Power frequency is 50Hz, three-phase AC 380V. (220V power source with the headquarters of the technical center to confirm the further communication. The deviation of rated voltage and rated frequency is no more than 5%.

2. Sewage debris (including flexible debris and small solid particles) shall be able to flow in the pipeline.

3. The sewage temperature can not exceed 40℃, the density of the medium is not more than 1050Kg/m<sup>3</sup> (such as the density of the parameters of the pump must be considered separately), PH value in the range of 5-9.

4、控制柜环境温度不超过80℃。

5、若连接的市政排污管道高于装置所处位置（地下室，商场负层等），则应设置防倒流管路（图中1），排气孔应设管路连接至外部大气（图中2）。

4. Control cabinet environmental temperature is not more than 80℃.

5. If the connection of the municipal sewage pipe is higher than the device location (basement, shopping malls, etc.), should be set up to prevent backflow pipeline (Figure 1), the exhaust hole should be set up in line to the external atmosphere (Figure 2).

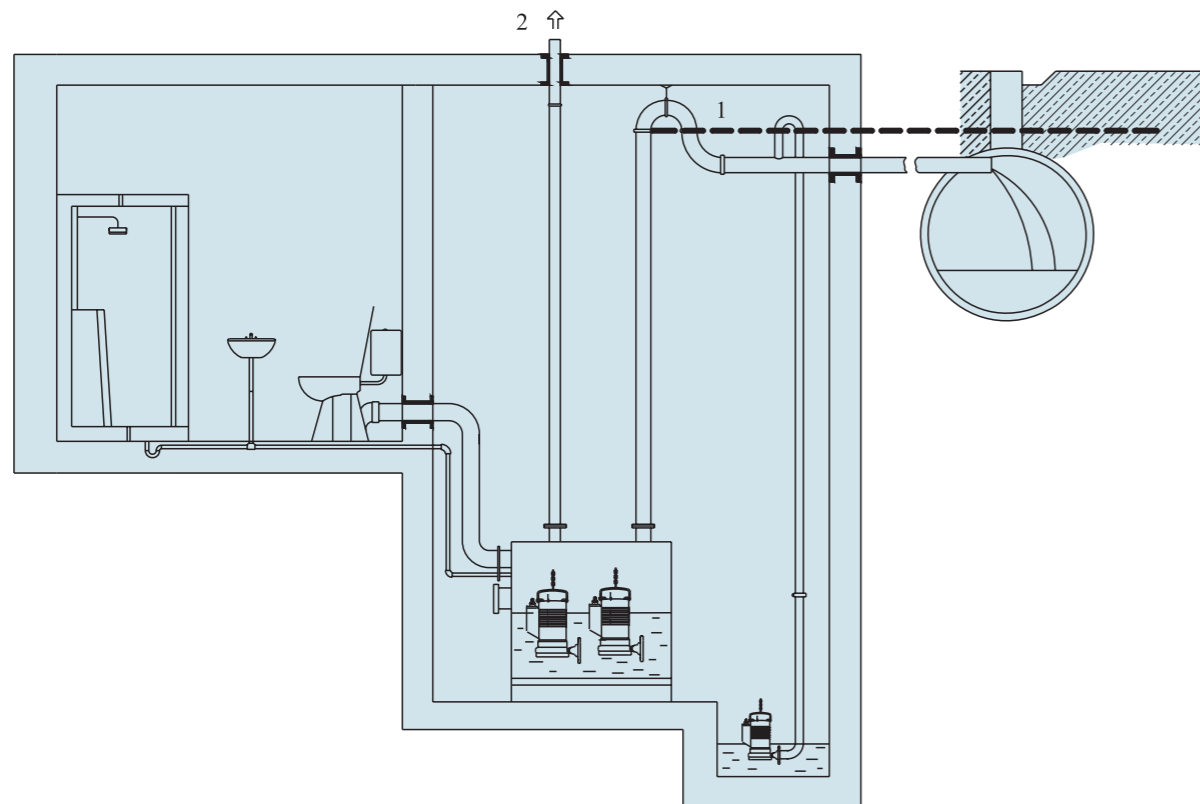

## 工作原理 Working principle

含有杂质的污水由进水口直接进入污水储存箱，达到单泵启动液位时，此液位的浮子开关上浮接通内部触点，发出信号，经控制柜处理后，启动一台排污泵，直至液位下降到停泵液位，泵停止运行。

若进入污水提升装置的污水流量较大，单台泵流量小于进入流量，则液位会持续上升至双泵启动液位，双泵启动液位的浮子开关发出信号，经控制柜处理后启动两台排污泵，两泵并联运行，直到液位下降至停泵液位。

Containing impurities in the sewage from the inlet directly into the waste water storage tank, to achieve single pump start level, the level of the float switch floating through internal contacts, signal, the processing control cabinet, start a sewage pump, until the level down to stop the pump level, the pump stops running.

If entering the sewage lifting device for sewage flow is large, single pump flow rate less than into the flow, liquid level will continue to rise to double pump start level, double pump start the liquid level float switch signal. After processing control cabinet, start two sewage pump, two pumps in parallel operation, until the level fell to stop the pump level.

污水储存箱内的气体经由通气孔排出，此通气孔与大气连通，还能防止形成负压。

合理的入口管路设计与流量搭配使得两泵运行时流量总是大于入口流量，因此液位至多只会达到双泵启动液位浮子开关处。泵发生故障，浮球开关漂离本有位置，浮球开关发生故障，内管路损坏等情况发生时，浮子开关接触到水，发出报警信号，提醒值班人员停机检修。

浮球开关可换为液位开关（推荐小箱体中使用），若合同中未指出使用何种液位控制开关，则我司可根据实际生产状况决定使用何种开关。

The gas in the storage tank is discharged through the vent, which is connected with the atmosphere and can prevent the formation of negative pressure.

Reasonable inlet piping design and traffic mix the two pump operation when traffic is always larger than the inlet flow. Therefore, liquid level at most only reached double pump to start the float level switch. Pump failure, floating ball switch drift away from this position, the floating ball switch failure, in pipeline damage occurs, the float switch comes into contact with water, emit an alarm signal remind personnel on duty downtime.

Float switch can be changed into liquid level switch (recommended for small box), if the contract does not point out the use of liquid level control switch, we can according to the actual production status of the switch.

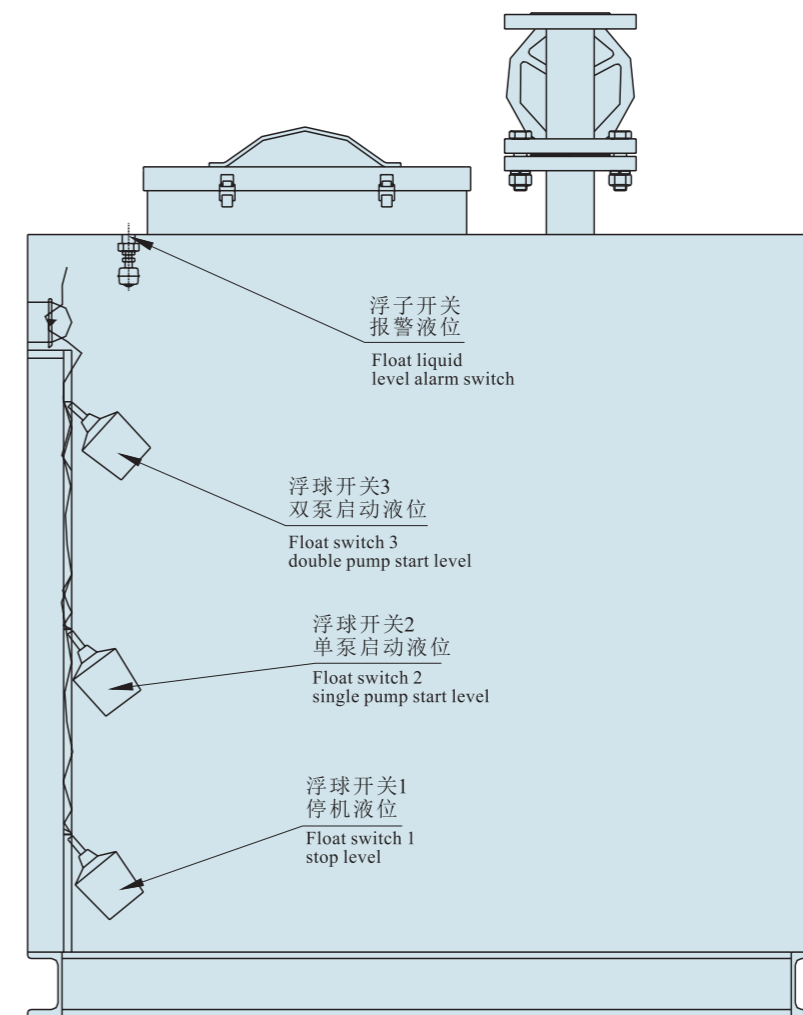

WTG型污水提升装置结构图 Structure diagram of WTG type sewage lifting device

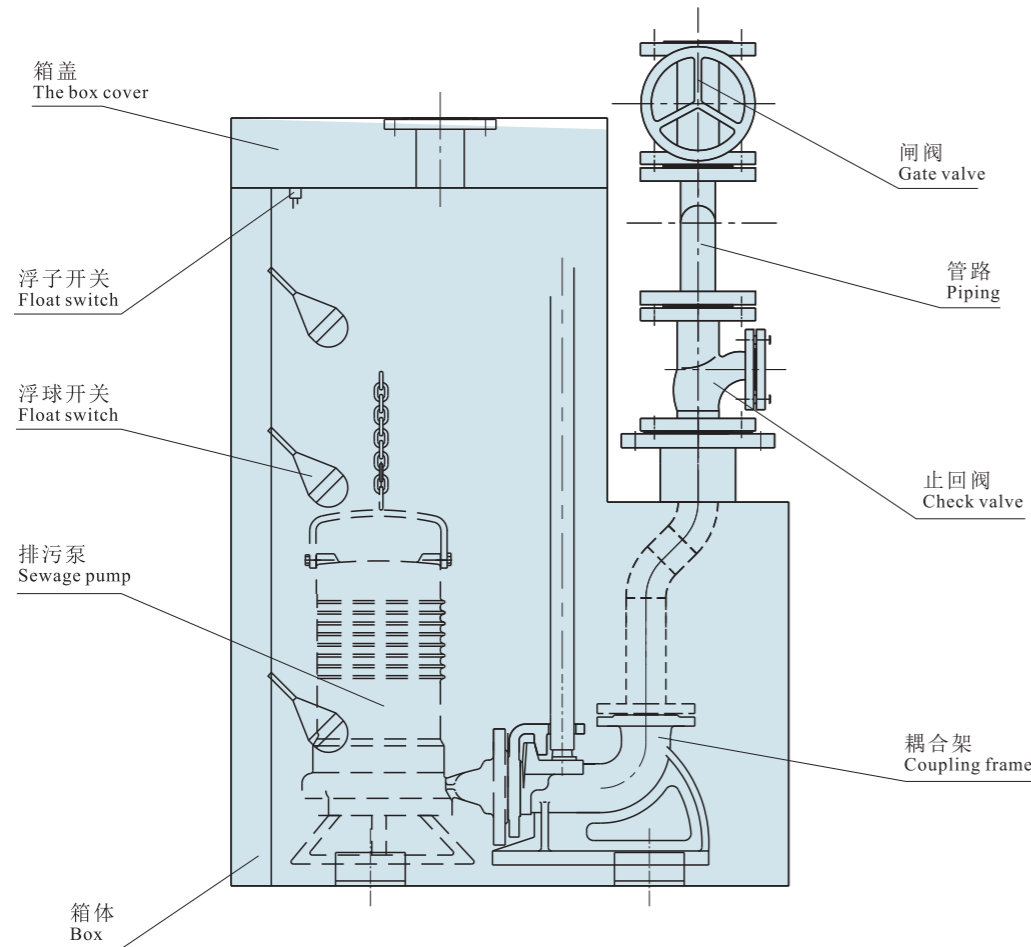

产品配置表 Product configuration table

序号 No	名称 Name	数量 Number	备注 Remarks
1	排污泵 Sewage pump	1/2 台 Piece	
2	污水收集箱 Sewage collection box	1	
3	箱盖 The box cover	1	
4	电控柜 Electric control cabinet	1	LEC-2AcS-WT-N
5	浮球液位控制器 Float ball liquid level controller	1套 Set	
6	浮子开关 Float switch	1个 Piece	
7	闸阀 Gate valve	1	
8	止回阀 Check valve	1/2	
9	管路 Piping	1套 Set	
10	耦合架 Coupling frame	1/2套 Set	

性能参数表 Performance parameter

型号 Model	箱体名义容积 Nominal capacity of box	水泵 Water pump				
		型号 Model	单泵流量 Single pump flow (m <sup>3</sup> /h)	单泵扬程 Single pump head (m)	单泵功率 Single pump power (KW)	泵台数 Pump number
250WTG-1-7/7	250	40WQX7-7-0.75	7	7	0.75	1
250WTG-1-8/10	250	40WQX8-10-1.1	8	10	1.1	1
250WTG-1-8/15	250	40WQX8-15-1.5	8	15	1.5	1
250WTG-1-15/7	250	50WQX15-7-1.1	15	7	1.1	1
250WTG-1-15/11	250	50WQX15-11-1.5	15	11	1.5	1
250WTG-1-15/16	250	50WQX15-16-2.2	15	16	2.2	1
250WTG-1-15/22	250	50WQX15-22-3	15	22	3	1
250WTG-1-15/30	250	50WQX15-30-4	15	30	4	1
400WTG-2-7/7	400	40WQX7-7-0.75	7	7	0.75	2
400WTG-2-8/10	400	40WQX8-10-1.1	8	10	1.1	2
400WTG-2-8/15	400	40WQX8-15-1.5	8	15	1.5	2
400WTG-2-15/7	400	50WQX15-7-1.1	15	7	1.1	2
400WTG-2-15/11	400	50WQX15-11-1.5	15	11	1.5	2
400WTG-2-15/16	400	50WQX15-16-2.2	15	16	2.2	2
400WTG-2-15/22	400	50WQX15-22-3	15	22	3	2
400WTG-2-15/30	400	50WQX15-30-4	15	30	4	2
400WTG-2-25/25	400	50WQX25-25-5.5	25	25	5.5	2
400WTG-2-25/32	400	50WQX25-32-7.5	25	32	7.5	2
700WTG-2-15/7	700	50WQX15-7-1.1	15	7	1.1	2
700WTG-2-15/11	700	50WQX15-11-1.5	15	11	1.5	2
700WTG-2-15/16	700	50WQX15-16-2.2	15	16	2.2	2
700WTG-2-15/22	700	50WQX15-22-3	15	22	3	2
700WTG-2-15/30	700	50WQX15-30-4	15	30	4	2
700WTG-2-25/25	700	50WQX25-25-5.5	25	25	5.5	2
700WTG-2-25/32	700	50WQX25-32-7.5	25	32	7.5	2
700WTG-2-30/10	700	65WQX30-10-3	30	10	3	2
700WTG-2-30/15	700	65WQX30-15-4	30	15	4	2
700WTG-2-30/22	700	65WQX30-22-5.5	30	22	5.5	2
700WTG-2-30/30	700	65WQX30-30-7.5	30	30	7.5	2
1000WTG-2-15/7	1000	50WQX15-7-1.1	15	7	1.1	2
1000WTG-2-15/11	1000	50WQX15-11-1.5	15	11	1.5	2
1000WTG-2-15/16	1000	50WQX15-16-2.2	15	16	2.2	2
1000WTG-2-15/22	1000	50WQX15-22-3	15	22	3	2
1000WTG-2-15/30	1000	50WQX15-30-4	15	30	4	2
1000WTG-2-25/25	1000	50WQX25-25-5.5	25	25	5.5	2
1000WTG-2-25/32	1000	50WQX25-32-7.5	25	32	7.5	2
1000WTG-2-30/10	1000	65WQX30-10-3	30	10	3	2
1000WTG-2-30/15	1000	65WQX30-15-4	30	15	4	2
1000WTG-2-30/22	1000	65WQX30-22-5.5	30	22	5.5	2
1000WTG-2-30/30	1000	65WQX30-30-7.5	30	30	7.5	2

注：如需表以外其他规格切割泵与水箱匹配，需咨询总部技术中心。

Note: Other specifications, such as the need to match the specifications of the pump and water tank matching, the need to consult the technical center of the headquarters

性能曲线图 Performance curve

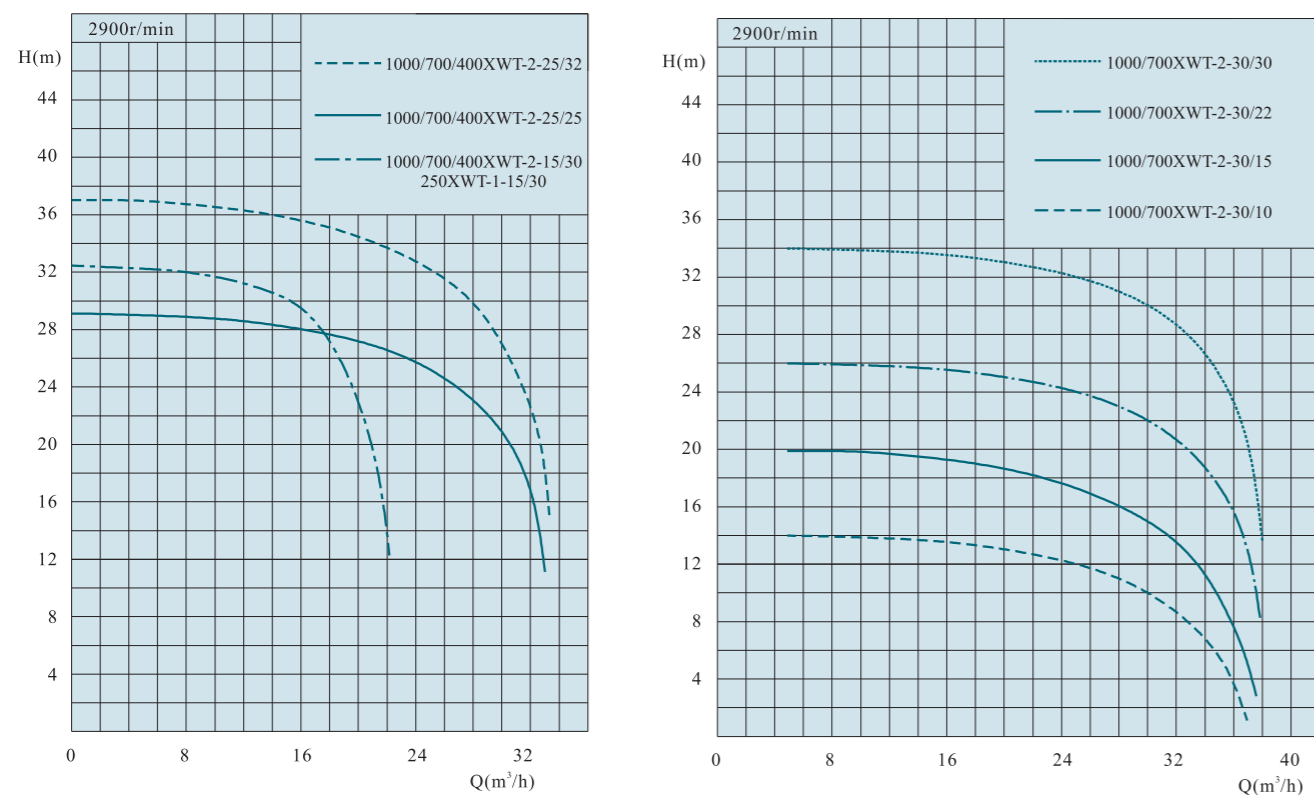
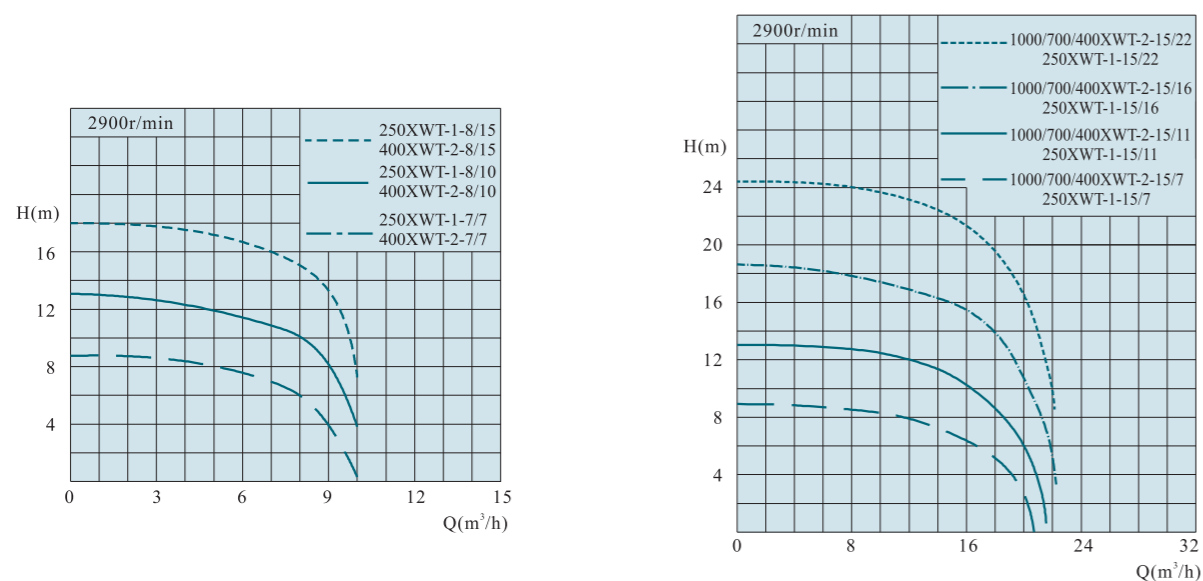

外形及安装尺寸图 Shape and installation dimension drawing

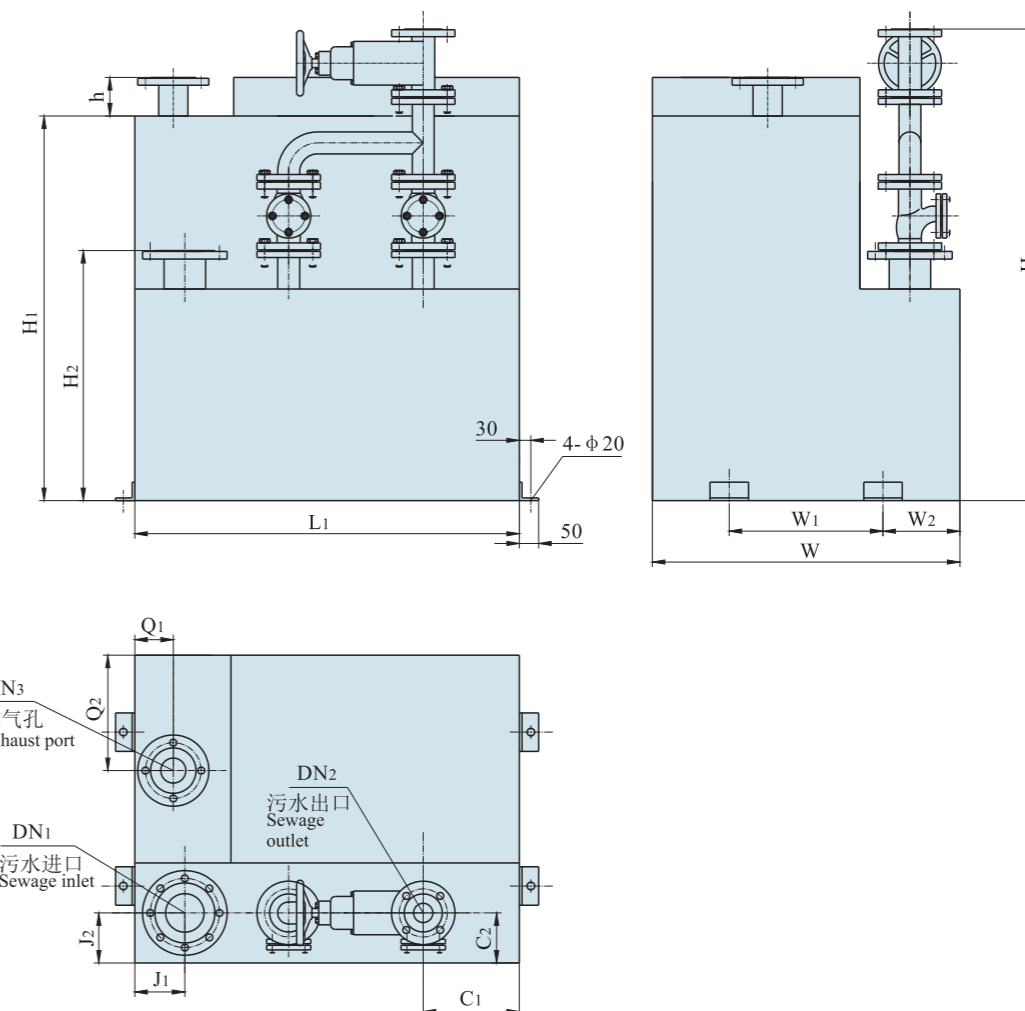

常规外形尺寸表 Regular shape dimension table

型号 Model	L1	W	W1	W2	H	H1	H2	h	J1*J2	C1*C2	Q1*Q2	DN1	DN2	DN3
800WTG-2-Q/H	1000	800	400	200	1300	1000	650	100	130*130	250*130	100*300	100	50	65
1200WTG-2-Q/H	1200	1000	600	200	1400	1000	650	100	130*130	250*130	100*300	100	65	65

注：具体外形图询技术中心。

Note: the specific appearance figure technology center.

## 服务网络

连成在全国各大、中城市设有350多个分支机构，并建立了销售服务网络，拥有一支庞大的销售服务队伍。

## 服务项目

- 技术培训
- 安装调试
- 维护修理保养
- 设备评估
- 故障处理
- 设备升级改造

## 服务承诺

- 合同签订后，在安装期间本公司将派人无偿到现场协助安装及调试；
- 如您按说明书正确使用上海连成牌水泵能确保您使用满意，万一发生异常情况，即请拨打服务热线，我们将为您提供优质的售后服务，给予你满意的答复；
- 产品保修期为一年，一年之内如产品出现质量问题，本公司将实行三包：一年以后出现产品质量问题，本公司提供无偿的技术服务，需方单位自购零配件；
- 产品售出后，本公司将终生与客户保持联系，听取使用意见，以便使产品质量更加完善；
- 本公司将定期与定购单位保持联系，定期回访，以确保定购单位使用的设备运行处于良好状态。

## Service Network

With a strong team of sales promotion and after-sales-service, Liancheng established more than 350 nation wide branches in various large and middle.

## Service Items

- Technical training
- Equipment evaluation
- Installation and adjustment
- Trouble-shooting
- Maintenance and repairing
- The modification & improvement of equipment

## Service Promise

After signing the contract, technical persons will be dispatched to the instant site to help install and adjust equipment, which is free of charge.

In case the equipment is manipulated in accordance with instruction of tech manual, Shanghai Liancheng will guarantee the products. If something abnormal occurred, please contact us. Shanghai Liancheng will provide consider. Within the warrant period of 1 year, if products have quality problems, Liancheng will provide charge-free services.

After warrant period, if quality problems occur, will provide the charge-free technical support, the components and parts should be bought by customers.

After the products are purchased, Shanghai Liancheng will keep lifelong contact with the customers, listening comments from customers so as to improve quality in pump performance.

Shanghai Liancheng will keep regular contact with ordering companies so as to have pump running in proper order.

## 境内售后服务请与我公司当地售后联系或总部：021-59136786

For the domestic post-sale service, please contact the local post-sale service and the headquarter: 021-59136786

## 境外销售和售后服务请联系：+86 21 59136780

For the abroad sale and post-sale service, please contact: +86 21 59136780

驻外机构：\_\_\_\_\_

Agency : \_\_\_\_\_